

# **Direkt**locs

OVERDENTURE ATTACHMENT SYSTEM

Technique Manual



## Welcome to the Direktlocs Attachment System Technique Manual

The Direktlocs Attachment System for denture retention is designed for the fixation of complete dentures (overdentures) or partial dentures that are fully or partially supported by endosseous implants in the mandible or maxilla. With the Direktlocs Attachment System, the patient has the possibility to remove and reinsert the denture.

Direktlocs abutments are compatible with a wide number of implant systems from leading manufacturers, ensuring a seamless integration and no change to your workflow.

Please note that the trademarks listed in this manual are property of their respective owners.

On the following pages you will find detailed instructions on how to use our system. Please do not hesitate to contact us if you need further information or have any questions and thank you for choosing Direktlocs for your patients.

Dental Direkt GmbH



## Content

<b>1. Information about the Direktlocs Attachment System</b>	<b>4</b>
<b>2. Intended purpose</b>	<b>5</b>
<b>3. System instructions</b>	<b>5</b>
<b>4. Working instructions Direktlocs Attachment System</b>	<b>6</b>
4.1 Position of the implant	6
4.2 Selection of the Direktlocs abutments	6
4.3 Determining the axial divergence between the implants	6
4.4. Selection of the abutments set	7
<b>5. Fabrication of a new full denture with the Direktlocs Attachment System</b>	<b>8</b>
5.1 Situational impression	8
5.2 Functional impression	9
5.3 Bite registration	11
5.4 Aesthetic fitting	11
5.5 Bonding in the mouth	12
<b>6. Reworking an existing complete denture with the Direktlocs Attachment System</b>	<b>13</b>
<b>7. Direktlocs bar abutment for milled bars</b>	<b>16</b>
7.1 Direktlocs bar abutment as an additional retention element on a milled bar in a new denture	16
7.2 Use of Direktlocs CAD/CAM bar abutment as an additional retention element on a milled bar for an existing denture	18
<b>8. Impression coping, closed tray</b>	<b>19</b>
<b>9. Use of the retention inserts</b>	<b>20</b>
<b>10. Presentation of the universal instruments for the Direktlocs Attachment System</b>	<b>21</b>
10.1 Direktlocs Four-piece Universal Instrument A0020	21
10.2 Direktlocs Two-piece Universal Instrument A0019	22
<b>11. Instructions for removing the retention inserts</b>	<b>22</b>
<b>12. Instruments for the Direktlocs Attachment System</b>	<b>23</b>
12.1 Screwdrivers for Direktlocs abutments with shank for contra-angle handpieces	23
12.2 Screwdriver with holding sleeve for Direktlocs abutments with shank for contra-angle handpieces	23
12.3 Hex screwdriver 1.25 mm with shank for contra-angle handpieces	23
12.4 Direktlocs angle measuring aid	23
12.5 Screwdriver with holding sleeve for Direktlocs ceramic abutments with shank for contra-angle handpieces	24
<b>13. Ancillary products</b>	<b>24</b>
<b>14. Packaging variants</b>	<b>27</b>
14.1 All-in-one-packaging	27
14.2 Direktlocs abutments individually packed in plastic vials	27
<b>15. Tightening torque in Ncm</b>	<b>27</b>
<b>16. Sterilization</b>	<b>28</b>
16.1 Abutments, cap, system screws:	28
16.2 Universal instruments, system tools, angle measuring tool	28
16.3 HPP retention inserts (PA12-GB30), block-out spacer	28
16.4 Direktlocs Attachment System retention insert nylon, other plastic parts:	28
<b>17. Prophylaxis</b>	<b>29</b>
<b>18. Patient</b>	<b>29</b>
<b>19. Description of symbols</b>	<b>30</b>

## 1. Information about the Direktlocs Attachment System

### Innovative Coating Technology (Patented)

Our patented fully biocompatible ceramic PVD (physical vapor deposition) coating provides many advantages over alternative abutment coatings. Comprised of a tremendously hard layer of Zirconium Carbonitride (ZrCN), the abutment coating is **more resistant to abrasion and wear** compared to other common coatings. Additionally, its impressive **rose gold tone blends well with the gingiva** and provides a premium appearance.

### Dual Abutment Drive Mechanism

In addition to the compatible tri-lobe drive mechanism, Direktlocs abutments feature a 1,25 mm hex drive mechanism in the center of the abutment for **simple seating using commonly available drivers**. This ensures that the abutments meet the needs of a wide variety of clinicians without requiring the purchase of additional tooling.

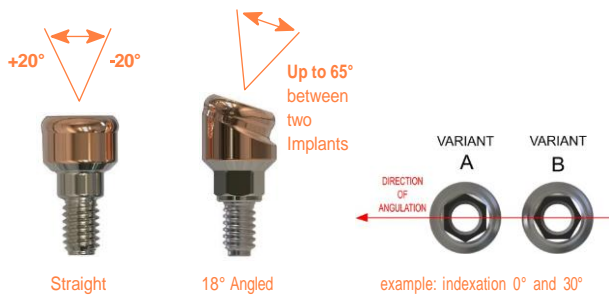
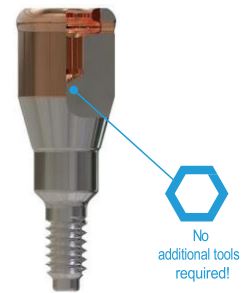

### 18° Angled Abutments

The availability of 18° angled abutments allows for the restoration of implants with up to 65° of divergence between them. This is a vast improvement over competitive systems that are not indicated for divergence over 20°. Further simplifying abutment placement are Direktlocs indexing features and set screws, which allow angled abutments to be quickly and **easily seated in the desired orientation**.

### Optimized retention housing

The retention housing has additional horizontal grooves for improved resistance to vertical and horizontal movement. The red anodized surface improves aesthetics and **prevents the grey surface shining through with the thin denture material**.

### High Performance Polyamide Retention Inserts

These retention inserts have a lower tendency to absorb moisture and a **high resistance** to chemicals, fats and alcoholic disinfectants. The inserts are **extremely durable** and have an **excellent dynamic load capacity**. For sterile procedures, they can be hot steam sterilized at 134°C.



### All-in-one packaging

Further adding to the convenience of the Direktlocs Overdenture Attachment System is the availability of all-in-one packaging that contains all of the necessary items to complete a case on a single tray. This includes a denture housing and retention inserts in every variation of force as well as a parallel post and convenient abutment carrier for angled abutments.



## 2. Intended purpose

### Indication

The Direktlocs attachment system for denture fixation is intended for the attachment of overdentures or partial dentures that are wholly or partially supported by endosseous implants in the lower or upper jaw.

### Contraindication

There are no absolute contraindications for the use of the attachment system for denture fixation. However, the product must not be used:

- if a complete fixation of the denture is requested.
- if only one implant is available to fix the denture.
- if the divergence between the implant axes is more than 40°.

## 3. System instructions

### Please pay attention!

This work instruction contains the current operating instructions. Please read them before using the Direktlocs Attachment System. The generally applicable planning principles apply for implant retained, combined mucosa/implant-supported, removable prosthetic restorations.

The Direktlocs system may only be used by dentists and doctors as well as dental technicians who are familiar with dental surgery, including diagnosis and preoperative planning. If there is any uncertainty regarding the indication or the type of application, it should not be used until all points have been clarified. Before each operation, make sure that all necessary parts, instruments and aids are suitable, complete and functional. All clinically used parts and instruments must be secured against aspiration and ingestion.

- The products are supplied **NON-STERILE**. Therefore, any prosthetic reconstruction must be cleaned and disinfected before use.
- The exact details can be found in section 16 Sterilization.
- This product must not be used in patients suspected of being allergic to one or more elements of the materials used.
- The product may only be used after prior allergological clarification and proof of the absence of an allergy.

### Single use of products

In general, products marked for single use must not be used more than once to avoid functional losses of the system!

**Retention inserts:** Retention inserts that show signs of abrasion or have been removed from the retention housing with the universal instrument are damaged and must be replaced.

**Direktlocs abutments:** Impurities on the abutment could lead to inflammation and infection in the patient or to increased wear in the retention area, which would result in a loss of retention of the denture.

## 4. Instructions for using the Direktlocs Attachment System

### 4.1 Position of the implant

The planning of implant positions is a prerequisite for an optimal restoration and the resulting patient satisfaction.

The strategic alignment of the implant positions should be chosen in such a way that the implants are widely distributed, thus ensuring polygonal support for the denture.

The restoration can be placed on two implants in the lower jaw. Make sure that the implants are placed as symmetrically as possible with sufficient interimplant space.

For the patient, the use of four instead of two implants is preferred. It reduces the risk of complications and stabilizes the prosthetic reconstruction against tensile, tilting and chewing forces.

At least four implants are required in the upper jaw. The distally planned implants should be placed as far distally as possible in order to achieve a maximum support polygon and to counteract any undesired tilting of the denture.

### 4.2 Selection of the Direktlocs abutments

The choice of Direktlocs abutment depends on the implant used, the thickness of the gingiva and the axial divergence between the implants.

If the axial divergence between the implants is greater than 20°, the angled Direktlocs abutment with 18° angulation is preferred. The correct abutment height is selected when the functional area is 1.5 mm out of the gingiva. It is easier for the patient to insert the denture if the abutments are at the same horizontal level.

Before inserting the Direktlocs abutment, please make sure that all bone and soft tissue is removed from the head of the implant. The abutment must be fully seated in the implant. Various instruments are available for inserting the abutment, which are described in sections 9, 10 and 11. The required tightening torque can be found in the table on page 29.



### 4.3 Determining the axial divergence between the implants

First, the blue parallelization pins are placed on the abutments. The angle measuring aid is then placed behind the parallelization pins and the axial divergence is read off. The value read is used for the correct selection of the abutment variant and shows which retention inserts are to be used.

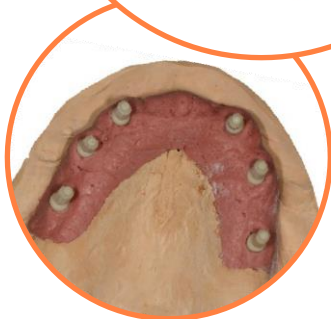

**NOTE:**  
Abutment selection aids are not suitable for intra-oral use!

#### 4.4. Selection of the abutments set

The correct selection of the implant abutment for each individual patient case is an important aspect of treatment success. The selection abutment set helps the dental technician to select the optimal Direktlocs abutment for the restoration. The appropriate angulation (straight or 18° angled) and connection indexing (type A or B if available) is determined. The label on the flag of the selection abutment stands for the respective Direktlocs counterpart that the dental technician must order.

The flag on the selection abutment shows the dental technician whether there is a common insertion direction.

## 5. Fabrication of a new full denture with the Direktlocs Attachment System

### 5.1 Situational impression

After the implants have healed and the gingiva formers have been inserted, the anatomical impression is taken using alginate impression material and a pre-fabricated tray.



- The anatomical plaster model is fabricated in the laboratory, on the basis of which an individual tray is made.



- The dental technician applies a placeholder for the impression material in the form of a wax plate in the area of the recognizable gingiva former. They design this area to be cylindrical in order to gain sufficient space for the closed impression using the Direktlocs impression caps.



- Now an individual tray made of dimensionally stable material is created, which serves for functional impression taking and transfer of the implant position.

## 5.2 Functional impression



- After removing the healing caps, the appropriate Direktlocs abutments are inserted (disinfection).

Make sure that the Direktlocs abutments have a consistent horizontal height.

Select the corresponding gingiva heights to achieve a uniform horizontal height level for all Direktlocs. In unfavorable situations, you can also choose between straight and angled Direktlocs.

The selection made must be documented so that it can be recreated for the final bonding.

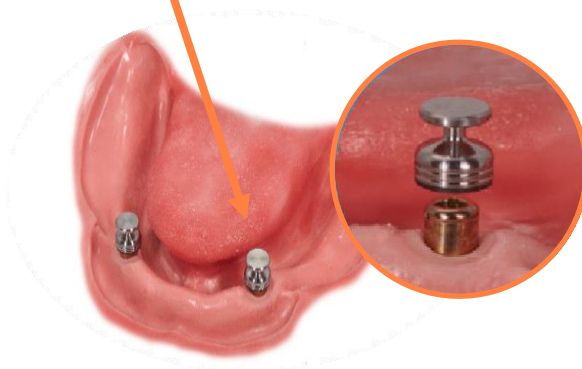

- Now place the impression cap on the Direktlocs. Pay attention to a firm fit free of play, recognizable by an audible click.

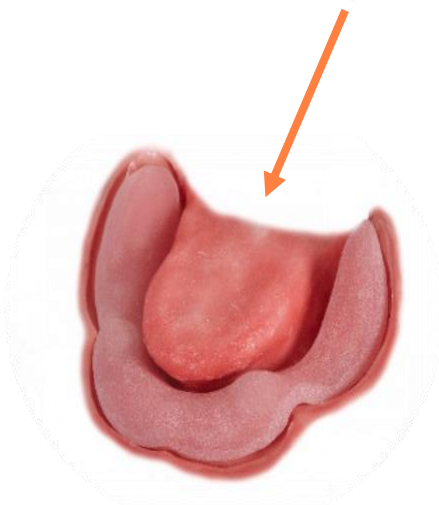

- Check the individual tray for its anatomical and tension-free fitting in the area of the Direktlocs.

## 5.2 Functional impression



- The impression should now be taken using light pressure and a stable impression material that allows the impression copings to be firmly located.



- After removing and checking the impression, the dental technician fabricates a master model from superhard plaster using the laboratory analogs, which are snapped in with an easily felt click.



- On this master model, the dental technician produces a bite registration with a resin base.



- In order to achieve optimum bite registration accuracy, it makes sense to incorporate the Direktlocs spacer sleeve, which serves as a placeholder until completion (small undercuts are used for retention). This ensures that the bite registration, as well as the subsequent wax set up, is firm and stable in the mouth.



### 5.3 Bite registration

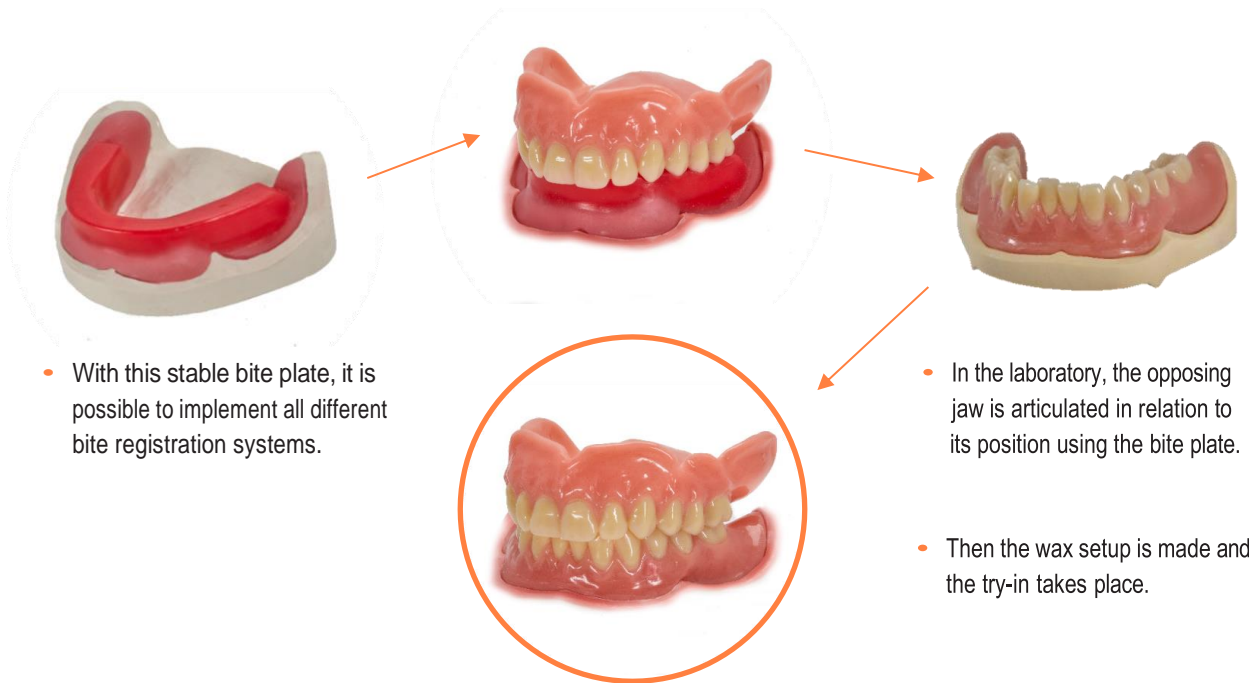

- With this stable bite plate, it is possible to implement all different bite registration systems.

- In the laboratory, the opposing jaw is articulated in relation to its position using the bite plate.
- Then the wax setup is made and the try-in takes place.

### 5.4 Aesthetic fitting



If it is aesthetically and functionally satisfactory for all parties, the dental technician can finish the denture using the placeholder.

- Check the correct fit and seal between the placeholder housing and the laboratory analog. If there is a gap, it can be closed with a little wax.
- After lifting off the polymerized denture, the placeholder is removed from the denture using the insertion and removal tool.

#### Removal of the placeholder:

- Use the removal tool of the Universal Instrument to remove the spacer sleeves from the finished denture. Use the same procedure when removing the spacer sleeve as you would when removing the colored retention insert from the retention housing.
- Do not angle the instrument but hold it straight when removing the spacer sleeves. This holds the instrument more firmly in the sleeve.
- Remove the spacer from the instrument by turning the removal tool further to the middle of the instrument (clockwise). This activates the removal pin that pushes the spacer sleeve off the instrument. Please point the instrument downwards and away from you.

Now the denture is finished for bonding the retention housing in the mouth.

## 5.5 Bonding in the mouth



- Sterilize the Direktlocs as described in section 16 and insert the appropriate gingival heights using the recommended torque and corresponding insertion tool.

Slide the white block-out rings over the functional area of the Direktlocs and place the red retention housing with the black processing insert on top. Check that the block-out spacer between the retention housing and the Direktlocs is seated and sealed correctly. If there is a gap, it can be closed with a second block-out spacer or some block-out wax. It is very important that no resin gets into the retention housing.

Now check the tension-free fit of the denture over the retention housings.

- To enable controlled bonding, it is advantageous to drill a small opening in the lingual / palatal area of the placeholder cavity. This allows for excess material to vent and ensures visually that the denture is fully seated.

- This hole can be drilled on the lingual or buccal surface (depending on access).

- To ensure an optimal hold, we recommend an abutment cement (e.g. Quick UP® QuickMix syringe 7.5 g by VOCO or similar). According to the adhesive manufacturer's instructions, prepare the housing and placeholder cavity of the denture, insert it and place the adhesive. After the cement has hardened, the denture can be removed and its function checked.

Then the remaining hole can be closed with pink denture resin and cleaned.

## 6. Reworking an existing complete denture with the Direktlocs Attachment System

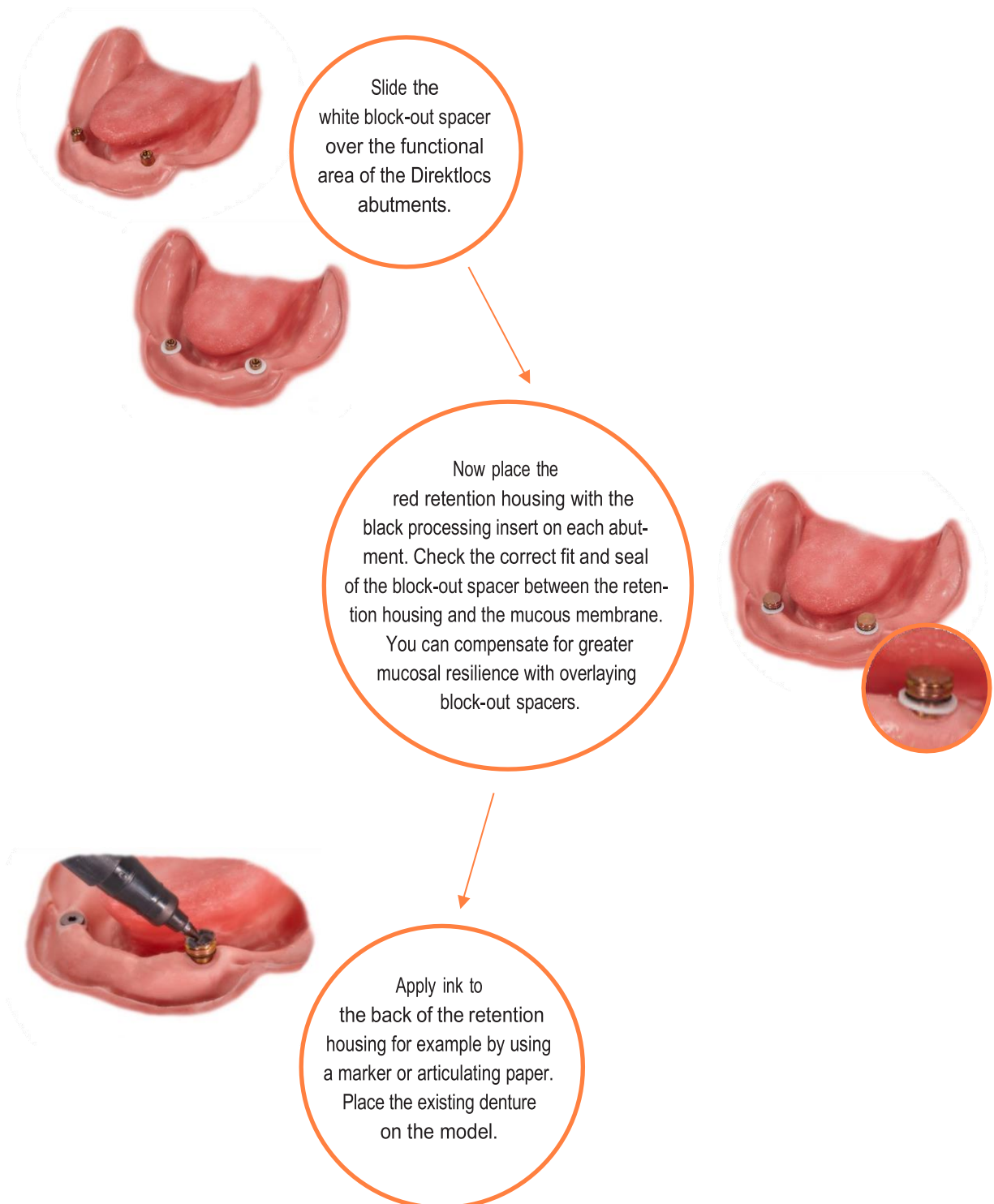



- The imprint of the ink on the denture base shows you the positions of the cavities for the fit of the retention housing.

- Grind out the cavities until the denture can be easily seated over the retention housing and a passive fit of the denture is achieved. The cavities for the retention housings must be large enough to prevent direct contact between the retention housing and the denture with a passive denture fit.

It is recommended to drill a connection hole to the cavities from the occlusal side. This allows for bonding to also take place from the occlusal side or for excess cement to vent through the hole.



- Bond the denture on the retention housings. For this purpose, place the denture over the retention housing in the oral cavity. The denture should have an optimal passive fit without exerting high pressure on the soft tissue.

You can fill the cavity between the retention housing with denture resin through the connecting holes. For this purpose, use cold-curing or light-curing resin and observe the manufacturer's instructions.

Alternatively, apply a small amount of this material to the milled cavities of the denture and coat slightly around the retention housings. Then place the denture in the oral cavity again. The position of the denture should not be changed until the resin has hardened.

After curing, remove the denture from the oral cavity and remove the white block-out spacers from the abutments. Now remove excess resin from the denture and re-polish it.



- Replace the black processing inserts with the selected retention insert using the universal instrument (see retention insert application).



- Insert the finished denture and check the occlusion. For initial treatment, you should choose a retention insert with lower retention force. Removal and replacement of the denture for cleaning purposes must be practiced with the patient.

## 7. Direktlocs bar abutment for milled bars



Direktlocs bar abutment with M2 screw thread and a head height of 2 mm.

### 7.1 Direktlocs bar abutment as an additional retention element on a milled bar in a new denture.



- Take an impression of the oral situation and fabricate a working cast according to the manufacturer's processing instructions.



- Design the bar using the CAD/CAM technique. Take into account the desired positions of the Direktlocs bar abutment.

A standard M2 thread is required in the bar to attach the bar abutment.

When designing the thread, pay attention to the insertion direction of the denture in the mouth. The bar abutment must rest on the bar.



- After fabrication of the CAD/CAM dental bar, the Direktlocs bar abutment is screwed into the milled bar using the Direktlocs screwdriver.

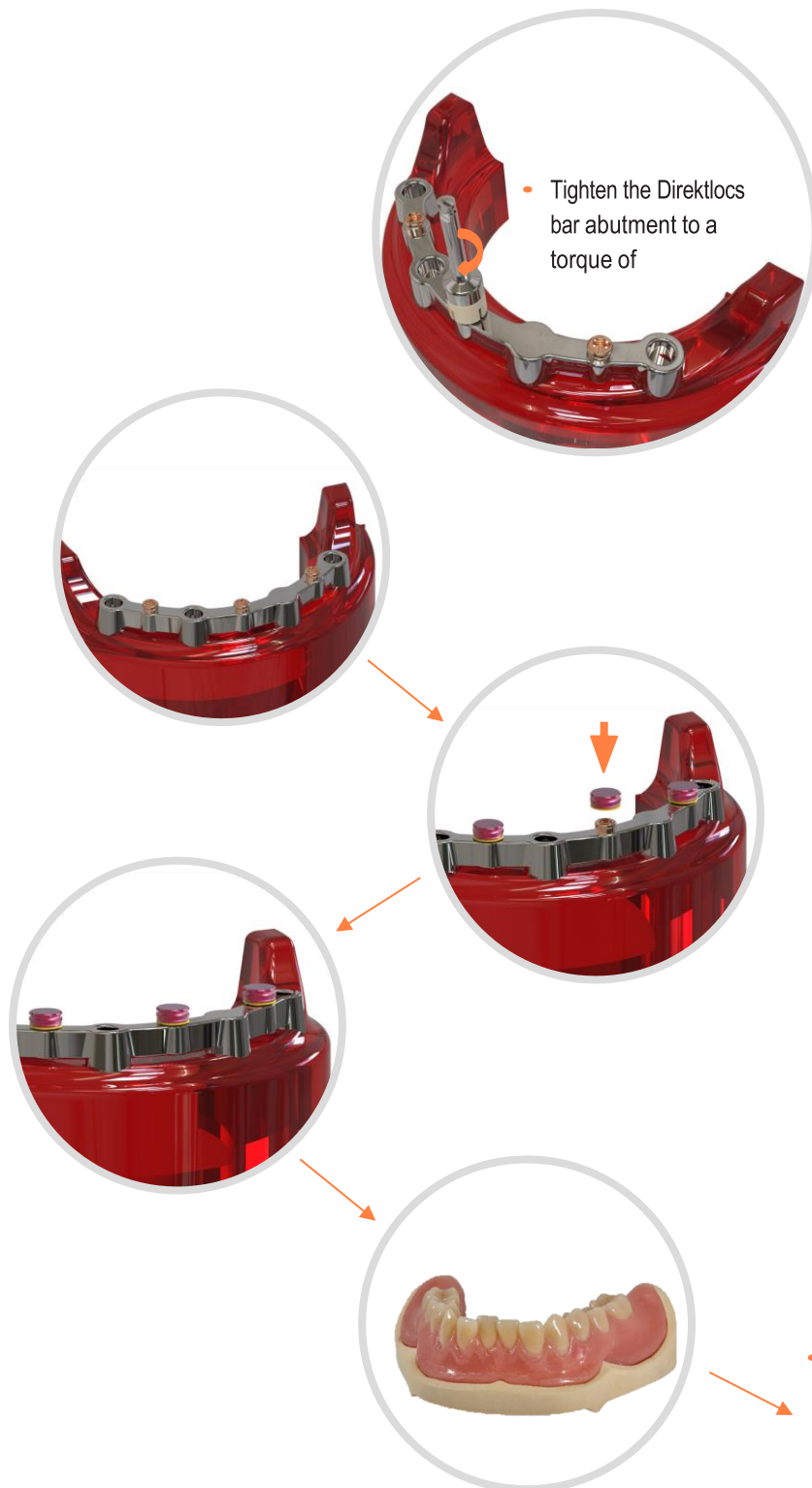

## 7.2 Use of Direktlocs CAD/CAM bar abutment as an additional retention element on a milled bar for an existing denture



Take a relining impression with the impression coping of the respective implant manufacturer and the denture to be remodeled.

Fabricate the model in extra hard dental stone plaster in a dental laboratory.

After fabricating the CAD/CAM dental bar, screw the Direktlocs bar abutment into the milled bar using the Direktlocs screwdriver.

Tighten the Direktlocs bar abutment to a torque of 35 Ncm.

After mounting the milled bar with the assembled Direktlocs bar abutments and the fixed retention housings on the master model, the denture is fitted over the bar construction with polymerization of the retention housings. The denture is then checked for excess acrylic in the area of the matrices and for proper functionality.

### Selection of retention inserts

Three different Direktlocs retention inserts are available for selecting the desired retention.

The retention inserts are color-coded. The color indicates the retention force that can be achieved with the retention inserts.



yellow: processing insert  
 blue: light retention (700 g),  
 pink: medium retention (1200 g)  
 clear: strong retention (2200 g)

- The data for the retention forces are approximate values.  
 Important: When trying the denture on the patient, always start with the lowest retention force.

## 8. Impression coping, closed tray

For transferring the implant position to the master model using the reduction technique (closed tray)



Impression copings in two lengths are available for taking the impression. The connecting screw is loosely connected to the impression coping.



The impression cap (reduction cap) is supplied together with the impression coping.

### Impression taking – Step by step



(1) The impression coping is inserted into the implant



(2) The retaining screw in the impression coping is tightened using the insertion tool



(3) The repositioning aid is applied to the impression coping after the correct fit has been rechecked



(4) Pressure is applied to the repositioning aid until it is fixed and locked in place



(5) The impression tray is applied to the repositioning aid and the impression coping.



(6) The impression tray is then removed, leaving the repositioning aid in the impression tray



(7) The impression coping is removed using the insertion tool



(8) The impression coping is placed in an analog and the retaining screw is tightened using the insertion tool



(9) The components are inserted into the repositioning aid, which is located in the impression tray, and fixed in place.









(10) The impression is moulded with the model material

## 9. Use of the retention inserts



The retention housing is supplied with a pre-assembled black processing insert, which is replaced by the selected retention insert with the Direktlocs universal instrument after the denture has been fabricated.

If subsequent work has to be carried out on the denture, the retention insert must be replaced by the processing insert. This is the only way to ensure that no contamination enters the retention housing. After work has been completed, the processing insert is replaced by a new retention insert.

Retention insert clear, pink, blue, for dual retention When anchoring on two or more Direktlocs attachments, the use of the blue or pink retention insert is recommended. When using the retention inserts with dual retention the maximum divergence of the accommodative Direktlocs abutments may not exceed 20°.			Retention insert grey	Retention insert red, orange, green, for extended pivot If there are implant axis divergences of more than 10-20° the extended pivot retention inserts should be used.		
						
MEDA0004	MEDA0003	MEDA0002	MEDA0001	MEDA0005	MEDA0006	MEDA0007
clear strong retention (*2200 g / 2.2 N)	pink medium retention (*1200 g / 1.2 N)	blue light retention (*700 g / 0.7 N)	zero retention for denture try-ins and protection. Do not use for the anchoring of the Direktlocs abutments long- term.	red light retention (*600 g / 0.6 N)	orange medium retention (*1000 g / 1.0 N)	green strong retention (*1900 g / 1.9 N)

The selection of the retention insert depends on the individually desired strength of the anchorage or retention.

Always start with the inserts with the least retention!

\* Different factors can lead to a deviation from the guide values



Removing the processing inserts  
To insert the retention inserts into the denture sockets you can remove the black processing inserts from the socket



Inserting the retention inserts  
Insert the retention inserts with the Direktlocs tool (see section 9).



Inserting the finished denture  
Insert the finished denture and check the occlusion

## 10. Presentation of the universal instruments for the Direktlocs Attachment System

### 10.1 Direktlocs Four-piece Universal Instrument MEDA0020

The Direktlocs universal instrument four-piece MEDA0020 boasts additional features such as the easy-to-clean surface, a holding sleeve and additional friction, which ensures secure retention of the retention insert on the instrument and thus considerably facilitates the insertion of the retention insert into the housing.



#### Holding sleeve

The instrument holding sleeve is screwed onto the end piece. It simplifies insertion of a Direktlocs abutment and holds it in place while it is screwed into the implant. The sleeve is made of PEEK and can be autoclaved.

#### Rose-gold end piece

The end piece of the instrument is used to screw the Direktlocs attachments into the implants or lab analogs. It is hardened and additionally refined with a very hard zirconium carbonitride coating.

#### Middle section

The middle section of the instrument is used to insert the retention insert into the retention housing. To do this, the removal tool must be completely unscrewed from the body. With the end, the retention insert is pressed into the retention housing. Additional friction holds the retention insert on the end.

#### Removal tool

The removal tool is used to remove the replacement inserts from the retention housing. To do this, the removal tool must be loosened with two full turns. A gap becomes visible between the removal tool and the middle section.

#### Rose-gold end piece with holding sleeve

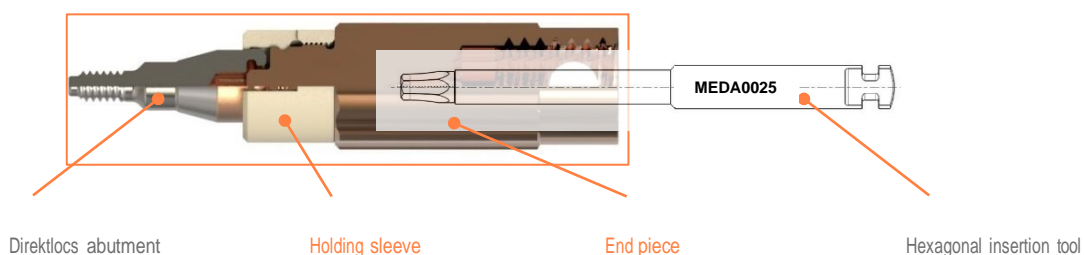

#### Holding sleeve:

The holding sleeve is screwed onto the end piece. It holds the Direktlocs abutment on the instrument when it is inserted into the implant. The holding sleeve can be easily screwed off the end piece for cleaning. If the holding function is not required, the end piece can also be used without the sleeve. The holding sleeve can be autoclaved.

#### End piece:

The end piece is fitted with a hexagon socket into which a hexagonal instrument with a size of 1.25 mm fits. A locking thread can be inserted through a cross hole. This can avoid aspiration.

## 10.2 Direktlocs Two-piece Universal Instrument MEDA0019

The tool is designed for use in the dental practice with the main focus on replacing retention inserts.



### End piece

The end piece of the instrument is used to insert the retention inserts into the housing. The removal tool does **not** have to be unscrewed from the end piece. With the end, the retention insert is pressed into the housing. Through additional friction, the retention insert is held at the end of the instrument.

### Removal tool

The removal tool is used to remove the retention inserts from the housing. To do this, the removal tool must be loosened with two full turns. A gap becomes visible between the removal tool and the end piece.

## 11. Instructions for removing the retention inserts

To remove the retention inserts, the removal tool must be turned from the body until a small gap between the two becomes visible. This ensures that the removal pin is far enough back in the removal tool.



The removal tool is then inserted vertically into the retention insert in the retention housing. The retention insert is removed from the retention housing with a slight tilting movement. The sharp edges of the tip hold the retention insert firmly on the removal tool.



By turning the removal tool clockwise on the middle section, the removal pin inside is pushed forward and thus pushes the retention insert from the removal tool.

### Holding element for retention inserts



A very special feature of Direktlocs universal instruments is the friction of the retention inserts on the instrument. The annoying dropping of the retention inserts during insertion into the housing is a thing of the past. With the instrument, the retention inserts can be removed directly from the packaging.

## 12. Instruments for the Direktlocs Attachment System

### 12.1 Screwdrivers for Direktlocs abutments with shank for contra-angle handpieces

The instrument is used to screw the one-piece straight Direktlocs abutments into the intended implants or implant analogs. It engages with the triangular geometry at the upper end of the abutment heads.

Material: hardened stainless steel  
Length: 30 mm  
Art. no.: MEDA0022



### 12.2 Screwdriver with holding sleeve for Direktlocs Abutments with shank for contra-angle handpieces

The instrument is used to screw the one-piece straight Direktlocs abutments into the intended implants or implant analogs. It engages with the triangular geometry at the upper end of the abutment heads. As an additional feature, the abutment is held on the instrument by the holding sleeve. The holding sleeve can be easily screwed off the end piece for cleaning. If the holding function is not required, the end piece can also be used without the sleeve. The holding sleeve can be autoclaved.

Material: hardened stainless steel; holding sleeve PEEK  
Length: 23.2 mm  
Diameter: Ø 5.8 mm  
Art. no.: MEDA0023



### 12.3 Hex screwdriver 1.25 mm with shank for contra-angle handpieces

For Direktlocs abutments and retaining screws

This instrument can be used to screw the one-piece straight Direktlocs abutments into the intended implants or implant analogs. The instrument is suitable for all Direktlocs retaining screws.

Material: hardened stainless steel  
Length: 27 mm  
Art. no.: MEDA0025



Not suitable for MEGAGEN screws MEDAANMST and MEDAANMSF

Not suitable for Botticelli screws MEDAPS028 and MEDAPR028

### 12.4 Direktlocs angle measuring aid

The angle measuring aid can be used to determine the angles (axial divergence) between the individual implants.

Material: steel  
Art. no.:  
MEDA0013



Secure the angle measuring aid to the lateral holes with dental floss in order to avoid aspiration.

## 12.5 Screwdriver with holding sleeve for Direktlocs ceramic abutments with shank for contra-angle handpieces



















### fits NobelPearl™, Zeramex® and SICwhite Direktlocs ceramic abutments



















The instrument is used to screw the one-piece straight Direktlocs ceramics abutments into the intended implants or implant analogs. It engages with the triangular geometry at the upper end of the abutment heads. As an additional feature, the abutment is held on the instrument by the holding sleeve. The holding sleeve can be easily screwed off the end piece for cleaning. If the holding function is not required, the end piece can also be used without the sleeve. The holding sleeve can be autoclaved.

Material: hardened stainless steel (1.4035); holding sleeve PEEK MT  
Coating: ZrCN/Length: 23.2 mm/Diameter: Ø 5.8 mm/REF: MEDA0027











## 13. Ancillary Products

REF	Quantity pieces	Denomination	material
MEDA0001S	8	Direktlocs retention insert, grey, no (0) retention	 PA12-GB30
MEDA0002S	8	Direktlocs retention insert, blue, light retention, 0°–10°	 PA12-GB30
MEDA0003S	8	Direktlocs retention insert, pink, medium retention, 0°–10°	 PA12-GB30
MEDA0004S	8	Direktlocs retention insert, clear, strong retention, 0°–10°	 PA12-GB30
MEDA0005S	8	Direktlocs retention insert, red, light retention, 10°–20°	 PA12-GB30
MEDA0006S	8	Direktlocs retention insert, orange, medium retention, 10°–20°	 PA12-GB30
MEDA0007S	8	Direktlocs retention insert, green, strong retention, 10°–20°	 PA12-GB30
MEDA0008S	8	Direktlocs processing insert black (not suitable for long-term use)	 HD-PE Purell
MEDA0001SZ	4	Direktlocs retention insert, grey, no (0) retention	 PA 6.6
MEDA0002SZ	4	Direktlocs retention insert, blue, light retention, 0°–10°	 PA 6.6
MEDA0003SZ	4	Direktlocs retention insert, pink, medium retention, 0°–10°	 PA 6.6
MEDA0004SZ	4	Direktlocs retention insert, clear, strong retention, 0°–10°	 PA 6.6
MEDA0005SZ	4	Direktlocs retention insert, red, light retention, 10°–20°	 PA 6.6
MEDA0006SZ	4	Direktlocs retention insert, orange, medium retention, 10°–20°	 PA 6.6
MEDA0007SZ	4	Direktlocs retention insert, green, strong retention, 10°–20°	 PA 6.6
MEDA0008SZ	4	Direktlocs processing insert black (not suitable for long-term use)	 LD-PE Purell
MEDA0009S	20	Direktlocs block-out ring	 Santoprene® TPE
MEDA0009SZ	20	Direktlocs block-out ring	Silicone
MEDA0010S	4	Titanium retention housing with processing insert	 Housing Titanium G5/HD-PE Purell
MEDA0010SZ	4	Titanium retention housing with processing insert	 Housing Titanium G5/LD-PE Purell
MEDA0010SZT	10		

MEDA0011SZ	4	Pink anodized titanium retention housing with processing insert		Housing pink/Titan G5 LD-PE Purell
MEDA0011SZT	10			
MEDA0030S	2	Zirconia retention housing with processing insert		Housing ZrO2/HD-PE Purell
MEDA0012S	4	Direktlocs spacer sleeve		Hostaform®/POM
MEDA0013	1	Direktlocs angle measuring aid		Stainless steel
MEDA0014S	4	Direktlocs Lab Analog straight		Titanium/Grade 5
MEDA0026S	4	Direktlocs Lab Analog angled 18°		Titanium/Grade 5
MEDA0015S	4	Direktlocs impression coping with black processing insert		Housing Titanium G5 HD-PE Purell
MEDA0016S	4	Direktlocs parallelization posts		HD-PE Purell
MEDA0019	1	Direktlocs Two-piece Universal instrument		Stainless steel/Silicone
MEDA0020	1	Direktlocs Four-piece Universal instrument		Stainless steel/ZrCN (rose-gold) PEEK/Silicone
MEDA0022	1	Screwdriver for Direktlocs abutments with shank for contra-angled handpieces		Stainless Steel
MEDA0023	1	Screwdriver with holding sleeve for Direktlocs abutments with shank for contra-angled handpieces		Stainless Steel/PEEK
MEDA0027	1	Screwdriver with holding sleeve for Direktlocs ceramic abutments with shank for contra-angled handpieces		Stainless steel/ZrCN (rosed-gold) PEEK
MEDA0025	1	Hex screwdriver 1.25 mm for Direktlocs abutments and retaining screws with shank for contra-angled handpieces <b>Not suitable for MEGAGEN screws AANMST and AANMSF</b>		Stainless steel
MEDA0050ST	1	Direktlocs laboratory set, up to 20° divergence compensation: 2 titanium housings (MEDA0010) (Ø 5.5 mm, height 2.5 mm) with black process insert (MEDA0008) (height 1.9 mm), 2 block-out rings (MEDA0009), 2 retention inserts, transparent (MEDA0004), 2 retention inserts, pink (MEDA0003), 2 retention inserts, blue (MEDA0002)		
MEDA0051ST	1	Direktlocs laboratory set, up to 40° divergence compensation: 2 titanium housings (Ø 5.5 mm, height 2.5 mm) with black process insert (height 1.9 mm), 2 block-out rings (MEDA0009), 2 retention inserts, green (MEDA0007), 2 retention inserts, orange (MEDA0006), 2 retention inserts, red (MEDA0005)		
MEDA0052ST	1	Direktlocs laboratory set, up to 20° divergence compensation: 2 zirconia housings (Ø 5.5 mm, height 2.5 mm) with black process insert (height 1.9 mm), 2 block-out rings (MEDA0009), 2 retention inserts, transparent (MEDA0004), 2 retention inserts, pink (MEDA0003), 2 retention inserts, blue (MEDA0002)		
MEDA0053ST	1	Direktlocs laboratory set, up to 40° divergence compensation: 2 zirconia housings (Ø 5.5 mm, height 2.5 mm) with black process insert (height 1.9 mm), 2 block-out rings (MEDA0009), 2 retention inserts, green (MEDA0007), 2 retention inserts, orange (MEDA0006), 2 retention inserts, red (MEDA0005)		

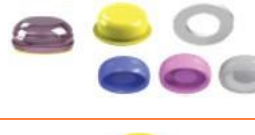
MEDA0055SZT MEDA0055TZT	2 10	Direktlocs laboratory set, up to 20° divergence compensation: 1 titanium housing (MEDA0010Z) (Ø 5.5 mm, height 2.5 mm) with black process insert (height 1.9 mm), 1 block-out ring (MEDA0009Z), 2 retention inserts, transparent (MEDA0004), 1 retention insert, clear (MEDA0004Z), 1 retention insert, pink (MEDA0003Z), 1 retention insert, blue (MEDA0002)	
MEDA0055SZTA MEDA0055TZTA	2 10	Direktlocs laboratory set, up to 20° divergence compensation: 1 titanium housing (MEDA0011Z), pink anodized (Ø 5.5 mm, height 2.5 mm) with black process insert (height 1.9 mm), 1 block-out ring (MEDA0009Z), 1 retention insert, clear (MEDA0004Z), 1 retention insert, pink (MEDA0003Z), 1 retention insert, blue (MEDA0002)	
MEDA0056SZT MEDA0056TZT	2 10	Direktlocs laboratory set, up to 40° divergence compensation: 1 titanium housing (MEDA0010Z) (Ø 5.5 mm, height 2.5 mm) with black process insert (height 1.9 mm), 1 block-out ring (MEDA0009Z), 1 retention insert, green (MEDA0007Z), 1 retention insert, orange (A0006.Z), 1 retention insert, red (MEDA0005Z)	
MEDA0056SZTA MEDA0056TZTA	2 10	Direktlocs laboratory set, up to 40° divergence compensation: 1 titanium housing (MEDA0011Z), pink anodized (Ø 5.5 mm, height 2.5 mm) with black process insert (height 1.9 mm), 1 block-out ring (MEDA0009Z), 1 retention insert, green (MEDA0007Z), 1 retention insert, orange (MEDA0006Z), 1 retention insert, red (MEDA0005Z)	

## Bar components

REF	Quantity pieces	Denomination	
MEDA0102ST	1	Direktlocs Abutment Set A, one-piece abutment 1 piece Direktlocs bar abutment (MEDA0102) 1 retention housing (Ø 5.5 mm, height 2.5 mm) with yellow processing insert (MEDA0017) 1 block-out ring (MEDA0009), 1 retention insert, blue (MEDA0002), 1 retention insert, pink (MEDA0003), 1 retention insert, transparent (MEDA0004),	
MEDA0102S MEDA0102Z	2 10	Direktlocs abutment for bar, 2.0 mm thread	
MEDA0050SBT MEDA0050TBT	1	Direktlocs laboratory set, up to 20° divergence compensation: 2 titanium housings (MEDA0010) (Ø 5.5 mm, height 2.5 mm) with yellow bar process insert (height 1.9 mm), 2 pieces block-out ring (MEDA0009), 2 pieces retention inserts, transparent (MEDA0004), 2 retention inserts, pink (MEDA0003), 2 retention inserts, blue (MEDA0002)	
MEDA0057SZT MEDA0057TZT	2 10	Direktlocs laboratory set, up to 20° divergence compensation: 1 titanium housing (MEDA0010Z) (Ø 5.5 mm, height 2.5 mm) with yellow bar process insert (height 1.9 mm), 1 piece block-out ring (MEDA0009Z), 2 pieces retention inserts, transparent (MEDA0004), 1 retention insert, clear (MEDA0004Z), 1 retention insert, pink (MEDA0003Z), 1 retention insert, blue (MEDA0002)	
MEDA0057SZTA MEDA0057TZTA	2 10	Direktlocs laboratory set, up to 20° divergence compensation: 1 titanium housing (MEDA0011Z), pink anodized (Ø 5.5 mm, height 2.5 mm) with yellow bar process insert (height 1.9 mm), 1 block-out ring (MEDA0009Z) retention insert, transparent (MEDA0004Z), 1 retention insert, pink (MEDA0003Z), 1 retention insert, blue (MEDA0002)	
MEDA0017SZ MEDA0017SZT	4 20	Yellow bar processing insert	
MEDA0010SZB MEDA0010SZBT	4 10	Titanium retention housing with yellow processing insert for bar	
MEDA0011SZB MEDA0011SZBT	4 10	Pink titanium retention insert with yellow processing insert for bar	

## 14. Packaging variants

### 14.1 All-in-one-packaging

---

**Set A Direktlocs Abutment Set A, one-piece abutment**

- 1 Direktlocs abutment (xxxxxx)
- 1 retention housing (Ø 5.5 mm, height 2.5 mm) with black processing insert
- 1 block-out ring (MEDA0009)
- 1 Direktlocs parallelization pin (MEDA0016)
- 1 retention insert, blue (MEDA0002)
- 1 retention insert, pink (MEDA0003)
- 1 retention insert, transparent (MEDA0004)
- 1 retention insert, red (MEDA0005)
- 1 retention insert, orange (MEDA0006)
- 1 retention insert, green (MEDA0007)

(the black processing insert is not suitable for permanent use in the mouth)



---

**Set B Direktlocs Abutment Set B, abutment with retaining screw**

- 1 Direktlocs abutment, angulation 18° (xxxxxx)
- 1 Direktlocs retaining screw (MEDA01xx)
- 1 holding pin (MEDE0000)
- 1 retention housing (Ø 5.5 mm, height 2.5 mm) with black processing insert
- 1 block-out ring (MEDA0009)
- 1 Direktlocs parallelization pin (MEDA0016)
- 1 retention insert, red (MEDA0005)
- 1 retention insert, orange (MEDA0006)
- 1 retention insert, green (MEDA0007)

(the black processing insert is not suitable for permanent use in the mouth)



For the MEGAGEN All-in-one packaging set B, a laboratory screw is additionally packed.

### 14.2 Direktlocs abutments individually packed in plastic vials

- The straight Direktlocs abutments are individually packaged in plastic vials.
- The angled Direktlocs abutments are packaged in the plastic vial together with the retaining screw.

## 15. Tightening torque in Ncm

The current tightening torques can be found in the operating instructions Fo\_00100

**Important! The specified tightening torque must always be checked again after 5 minutes and corrected if necessary.**

## 16. Sterilization

Please note that all abutments and components are supplied **NON-STERILE**. The following sterilization procedures should be used before use:

### 16.1 Abutments, cap, system screws

Method	Procedure	Temperature	Minimum holding time *	Drying period
superheated steam	vacuum process (3x fractionated fore-vacuum)	134°C	5 minutes	20 minutes
superheated steam	vacuum process (3x fractionated fore-vacuum)	132°C	4 minutes	20 minutes

\* Indicated are the minimum holding times. The operating times are longer and may vary on the instrument side.  
Read the manufacturer's information and instructions for cleaning/sterilizing Surgical Instruments and prosthetic components.

### 16.2 Universal instruments, system tools, angle measuring tool

Method	Procedure	Temperature	Minimum holding time *	Drying period
superheated steam	vacuum process (3x fractionated fore-vacuum)	134°C	5 minutes	20 minutes
superheated steam	vacuum process (3x fractionated fore-vacuum)	132°C	4 minutes	20 minutes

Instruments should only be autoclaved or sterilized when dismantled.

\* Indicated are the minimum holding times. The operating times are longer and may vary on the instrument side.  
Read the manufacturer's information and instructions for cleaning/sterilizing Surgical Instruments and prosthetic components.

### 16.3 HPP retention inserts (PA12-GB30), block-out spacer

Method	Procedure	Temperature	Minimum holding time *	Drying period
superheated steam	vacuum process (3x fractionated fore-vacuum)	134°C	5 minutes	20 minutes
superheated steam	vacuum process (3x fractionated fore-vacuum)	132°C	4 minutes	20 minutes

\* Indicated are the minimum holding times. The operating times are longer and may vary on the instrument side.  
Read the manufacturer's information and instructions for cleaning/sterilizing Surgical Instruments and prosthetic components.

### 16.4 Direktlocs Attachment System retention insert nylon, other plastic parts

The nylon (PA6.6) retention inserts, the processing inserts and the parallelization pin cannot be sterilized in an autoclave. The products must be chemically disinfected, otherwise the function of the products may be impaired. This also includes the combination products such as the retention housings and the impression coping with integrated black/yellow processing insert.

Disinfection:

Use only disinfectants with tested efficacy according to EN ISO 15883 or with VAH/DGHM or FDA approval or CE marking. Always follow the information, instructions and warnings of the respective manufacturer of the disinfectant.

### **Validated procedure for the disinfection of products that cannot be sterilized:**

Recommended disinfectant: Cidex® OPA from JOHNSON & JOHNSON GMBH.

(Cidex® OPA is a registered trademark of Johnson & Johnson).

- Completely immerse the medical device in CIDEX® OPA solution at room temperature (20°C) for at least 5 minutes so that all lumens are filled and all air bubbles are eliminated. Remove the product from the solution and rinse thoroughly according to the following rinsing instructions.
- After removing the medical device from the CIDEX® OPA solution, immerse it completely in 1 liter of demineralized water. Then rinse the medical device under running water for 30 seconds.
- Repeat both steps: immersion and rinsing, once more so that the disinfectant is completely removed.
- After the second rinse, proceed with a final rinse for 10 seconds in isopropanol 70%.

## 17. Prophylaxis



















The long-term success of the Direktlocs Attachment System depends in particular on the maintenance of the system. The system should be inspected every 6 months (if necessary also at shorter intervals). The system should be thoroughly checked on these occasions. It is important that the abutments are cleaned of any debris as this could lead to premature wear of the retention inserts. The abutments should only be cleaned with plastic instruments. Metal instruments can scratch or roughen the abutment surface, which can also lead to increased abrasion of the retention inserts. The sulcus area on the abutment and the implant shoulder should also be checked regularly and cleaned if necessary. Check the exact seating of the abutment in the implant and the tightening torque and correct it if necessary.

It is also very important to check the retention inserts for wear. Excessive wear of the retention inserts may indicate a malfunction that needs to be corrected. Particles caused by abrasion of the abutments can adhere to the surface of the retention inserts.

## 18. Patient

The patient's oral hygiene and compliance can significantly impact the longevity of the Direktlocs Attachment System. Therefore, it is crucial for them to learn home care maintenance. Removal and replacement of the denture should be practiced. It is important to show the patient how to handle the individual components and how to clean them. The abutments and the retention inserts may only be cleaned with a soft dental brush and a tooth gel. Under no circumstances should cleaning agents with abrasive particles be used. Flushing systems are very well suited for the cleaning of gaps.

## 19. Description of symbols

	Manufacturer
	Catalogue number / Article number
	Batch number
	Consult instruction for use
	Do not reuse
	European conformity mark with identification number of the notified body
	European conformity mark
	Non-sterile
	Caution, consult accompanying documents
	Date of Manufacture (see packing)
	Protected from moisture
	Protection from light
	Medical device labeling according to MDR (Medical Device Regulation)
QTY	Quantity [piece] (see packing)
	Federal law (USA) restricts this product to sale by or on the order of a dentist or physician.
	Conditionally MR safe
	Designation of origin
	Product identification number
	HBC (Healthcare Barcode)
	Distributor

 **Dental Direkt GmbH**  
**Industriezentrum 106-108**  
**32139 Sprengel**  
**-Germany-**  
**Phone: +49 (0) 5225 86319-0**  
**info@dentaldirekt.de**  
**www.dentaldirekt.de**

 **MEDEALIS GmbH**  
**Im Steinböhl 9**  
**69518 Abtsteinach**  
**-Germany-**  
**Phone: + 49 (0) 6207 2032 597**  
**office@medealis.de**  
**www.medealis.de**  
**SRN: DE-MF-000019555**

**COPYRIGHT and Product NAMES**  
 Design, layout, and images as well as the publications on the homepage are subject to German copyright law. Any use outside the legal provisions of the copyright law requires written permission. All trade names used are possibly registered trademarks and do not guarantee free usage.  
 Products marked with © are registered trademarks of the respective manufacturer.

Fo\_00070 Revision 15  
 Valid: from 14.02.2024